

MX-1424/1424EX/1824/1824EX

interM

PROFESSIONAL STEREO MIXER



FEATURES

- 6 MONO(MX-1424/1424EX), 10 MONO(MX-1824/1824EX) INPUT AND 4 STEREO INPUT
Any sound source of microphones, cassette decks, electronic guitars, organs can be applied to the channel input.
- MAIN MIX L/R AND ALT 3/4 OUTPUT
Main mix L/R and ALT 3/4 are provided for convenient use.
- 2 AUX RETURN AND 2 AUX SEND
For convenient use of external equipment, AUX SEND and AUX RETURN function are provided.
- CHANNEL EQUALIZER
The 3 band equalizer are designed for ± 15 dB control on mono input channel.
The 2 band equalizer are designed for ± 15 dB control on stereo input channel.
- SOLO FUNCTION OF ALL CHs
The SOLO function allows you to monitor through headphone any input channel after the channel fader.
- 7 BAND GRAPHIC EQUALIZER(ONLY 1424EX/1824EX)
For easy sound tuning with musical instrument, 7 band graphic equalizer is provided.
- DSP FUNCTION:8 PROGRAMMED EFFECT (ONLY 1424EX/1824EX)
Built-in, 24-bit DSP with 8 Selectable Presets including Reverb, Delay and Chorus.
- PHANTOM POWER(+48V)
Phantom power is provided for easy connection of condenser microphones requiring an external power supply.

SPECIFICATIONS

- ELECTRICAL * 0dB=0.775Vrms
 - Input Sensitivity/Impedance
 - Mic-60dB/4k Ω (BAL)
 - Line-20dB/10k Ω (BAL)
 - AUX+4dB/10k Ω (UNBAL)
 - Tape Return-10dBV/10k Ω (UNBAL)
 - Rated Output
 - Mix L/R+4dB/150 Ω (BAL)
 - ALT 3/4+4dB/75 Ω (UNBAL)
 - CTRL. Room+4dB/75 Ω (UNBAL)
 - AUX Send.....+4dB/75 Ω (UNBAL)
 - Insert0dB/600 Ω
 - Phone3mW/100 Ω
 - Frequency Response(+1dB, -2dB)20Hz~20kHz
 - T.H.D(20Hz~20kHz)0.1%
 - EIN-128dB
 - Tone Control
 - High(12kHz) ± 15 dB
 - Mid(2.5kHz) ± 12 dB
 - Low(80Hz) ± 15 dB
- GENERAL
 - Power SourceAC 120V/230V/240V, 50/60Hz
 - Power Consumption30W
 - WeightMX-1424(EX):7kg
MX-1824(EX):8kg
 - DimensionsMX-1424(EX):482(W)x90(H)x354(D)mm
MX-1824(EX):556(W)x90(H)x354(D)mm

MX-1424/1424EX/1824/1824EX

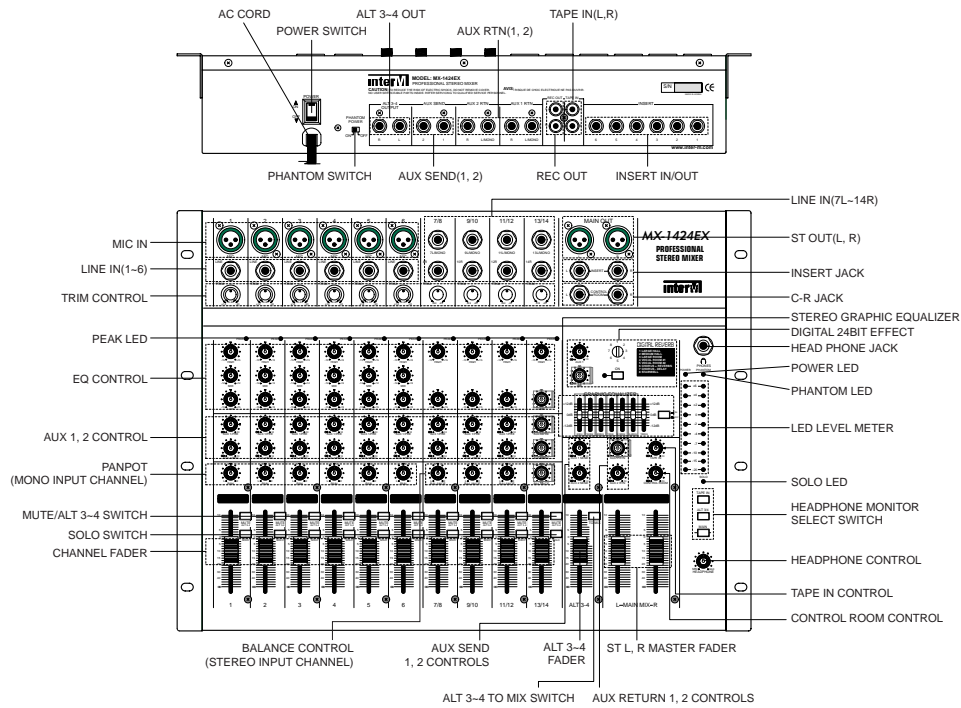

BLOCK DIAGRAM

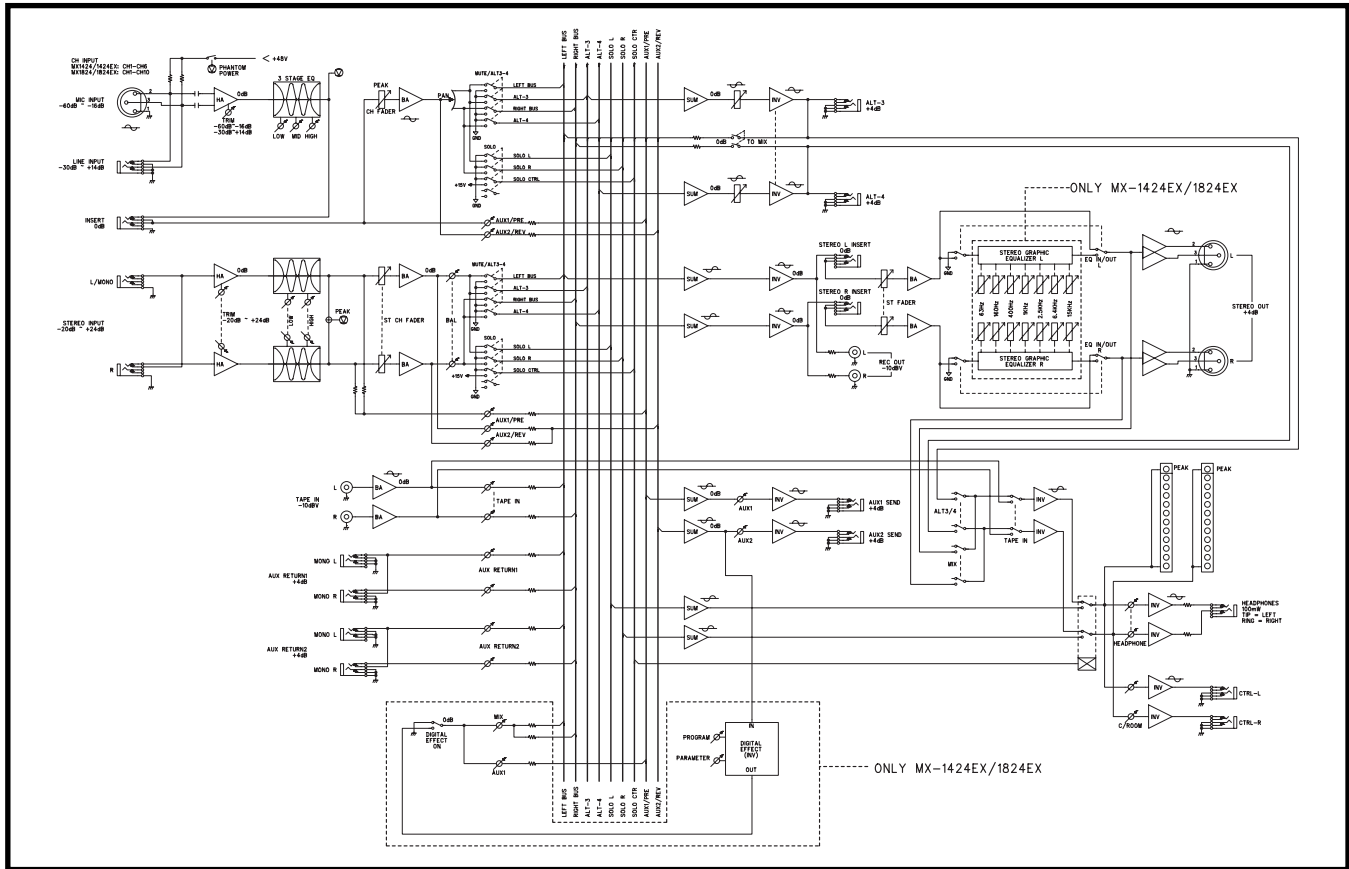

OFFICE : 653-5 BANGHAK-DONG, DOBONG-KU, SEOUL, KOREA TEL : 82-2-2289-8140~8, FAX : 82-2-2289-8149
 Home page : <http://www.inter-m.com> E-mail : export@inter-m.com